

About Microsiga

Microsiga Software is a Brazilian Company specializing in technology and systems development for enterprise management, with its sole focus on the corporate sector. With 20 years of proven technology and services, Microsiga is the undisputed market leader in Brazil and a key player in other Latin American countries. One of the main factors that contribute to Microsiga's ongoing success is that they offer products and solutions to companies of all sizes in all market segments.

microsiga
intelligence

one step ahead.

Company:

Microsiga

Industry:

Enterprise Resource Planning

Requirements:

Replication and cross-platform support

Application Overview

Advanced Protheus is a system composed of two applications: the application server (Protheus Server) and the interface (Remote). The 32-bit application server is responsible for managing the client connections, running the application logic, and controlling the database access, while the thin-client interface is responsible solely for the user interface. To customize the application logic, a proprietary language, AdvPI (Advanced Protheus language), was developed for use within this sophisticated system.

Advanced Protheus is split into four operational layers:

- Application Server
- Thin-Client Terminal
- Database
- APO Repositories

Application Server

The application server is the program responsible for compiling and running the AdvPI code. The AdvPI routines are stored in the APO repositories, which allows for dynamic loading and unloading of the routines as needed by the clients. System updates are easier because only the modified APO repositories need to be updated. This provides high performance with low server resource consumption. Besides the database dedicated to the end-user data repository (described below), the application server itself has an internal ISAM database to control the data dictionary.

Thin-Client Terminal

Remote is the application responsible for the user interface. There is no local processing,

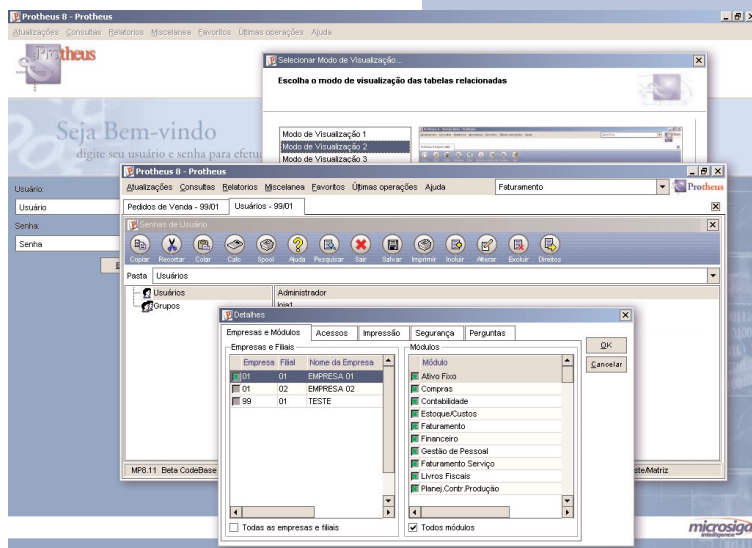

minimizing the network traffic between the terminal and the application server.

Database

The database access is performed through the application server, and it supports most commercial database options available today, including ISAM and SQL solutions. Transaction processing is required for database support. FairCom's c-tree Server is one of the options for the database. It is particularly well-suited for this purpose because it supports all platforms for which Advanced Protheus is available (including Windows, Linux, Sun, AIX, HP, and others) and offers both ISAM and SQL support.

APO Repository

The "Advanced Protheus Objects" repository is where the AdvPI programs or routines are located. This is the centralized location where the application can be customized or upgraded.

"c-tree's notification system allows us to provide distributed data access, bringing significant scalability enhancements to our solution"

Wilson de Godoy Soares, Jr.
Vice President, Microsiga



FairCom and Microsiga

Microsiga and FairCom have a close working relationship. Microsiga has chosen FairCom due to its flexibility, portability, performance, and reliance. FairCom is the only database available for use on Unix platforms (including Linux) for the control of the data dictionary, and it is now the default database for Windows as well.

Microsiga and FairCom worked closely for over a year on a number of aspects related to the Advanced Protheus project, including the integration of Microsiga's application server and the c-tree Server into a single executable. This new model, which Microsiga calls their Enterprise model, is a sophisticated enhancement to the standard Advanced Protheus model and is used in Microsiga's largest customer implementations.

The Details

Microsiga uses FairCom's c-tree Plus and c-tree Server as the default database to handle the internal dictionaries in the Application Server.

The base model, targeted at very small customers, uses the c-tree Plus standalone (non-server) mode. The next level uses the standard client/server model from FairCom. Finally, the Enterprise model allows for multiple c-tree Servers to be run in an asynchronous replication mode.

FairCom developed the ability to link the Application Server directly with the core c-tree Server. In essence FairCom has created a DLL (or Shared Object) version of the c-tree Server that can be linked with any multi-threaded client application. As a general rule, Microsiga's customers with up to 30 clients attached use a single Application Server. This solution has unmatched performance and the simplest possible installation procedure (i.e., no separate c-tree Server installation or configuration

since the server is linked together with the Application Server).

For larger customers, where more than one Application Server is necessary, Microsiga and FairCom, jointly developed the Enterprise Model using FairCom's notification process. This model uses a Master Server where the local database dictionary is stored and maintained on disk. The additional application servers' clients are connected to this Master Server, but they are also connected to local c-tree Servers ("Memory Servers") that are intended to operate only with a selected group of files in memory. These files are created and accessed in memory and never go to disk. The "real" database is maintained on disk in the Master Server.

At startup, each Application Server loads its Memory Files with the information stored in the Master Server. During normal operation, each client connecting to any Application Server will also keep a connection with the Master Server. All read operations for these selected files are directed to the "Memory Servers", which are linked with the Application Servers in one executable. Changes to records in these files are made on the Master Server, and FairCom's Notification feature ensures all Memory Servers are in sync. The asynchronous data replication among the "Memory Servers" and the "Master Server" ensures the servers inform each other of all updates.

Protheus Architecture

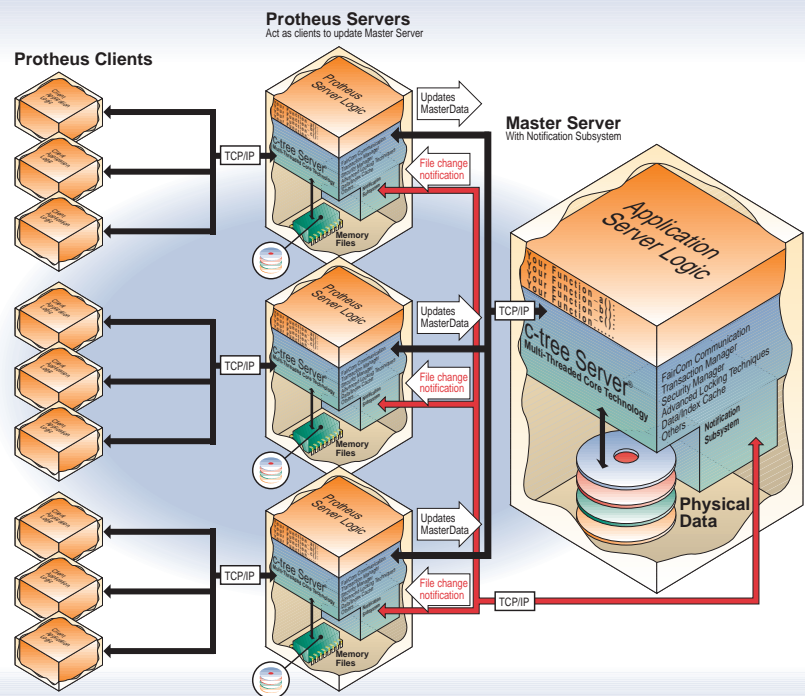

FairCom is pleased to work closely with customers like Microsiga to further improve both companies' technology. In recent years, several new features have been added to the FairCom product line as a result of specific projects developed with selected customers. In this case, the FairCom technology has been enriched with the practical application of new technologies like the DLL/SO c-tree Server model and, most notably, with the Notification process.



FairCom

www.faircom.com

FairCom Corporation

Tel: 573.445.6833
Fax: 573.445.9698
email: info@faircom.com

Business Hours:
9:00am - 5:00pm Mon.- Fri. (-6 GMT)

FairCom Europe S.r.l.

Tel: +39.035.721.321
Fax: +39.035.721.314
email: sales@europe.faircom.com

Business Hours: 09:00 AM - 12:30 PM &
02:00 PM - 06:30 PM Mon.- Fri. (+1 GMT)

FairCom Japan

Tel: +81.59.229.7504
Fax: +81.59.224.9723
email: query@faircom.co.jp

Business Hours: 0900 - 1200 &
1300 - 1800 Mon.- Fri. (+9 GMT)

FairCom Brazil

Tel: +55.11.3872.9802
Fax: +55.11.3875.1309
email: brasil@faircom.com

Business Hours:
0900 - 1700 Mon.- Fri. (-3 GMT)